

 **BEKAERT**

better together

Choosing the Right Fiber for Fiber Reinforced Concrete Precast Tunnel Segments

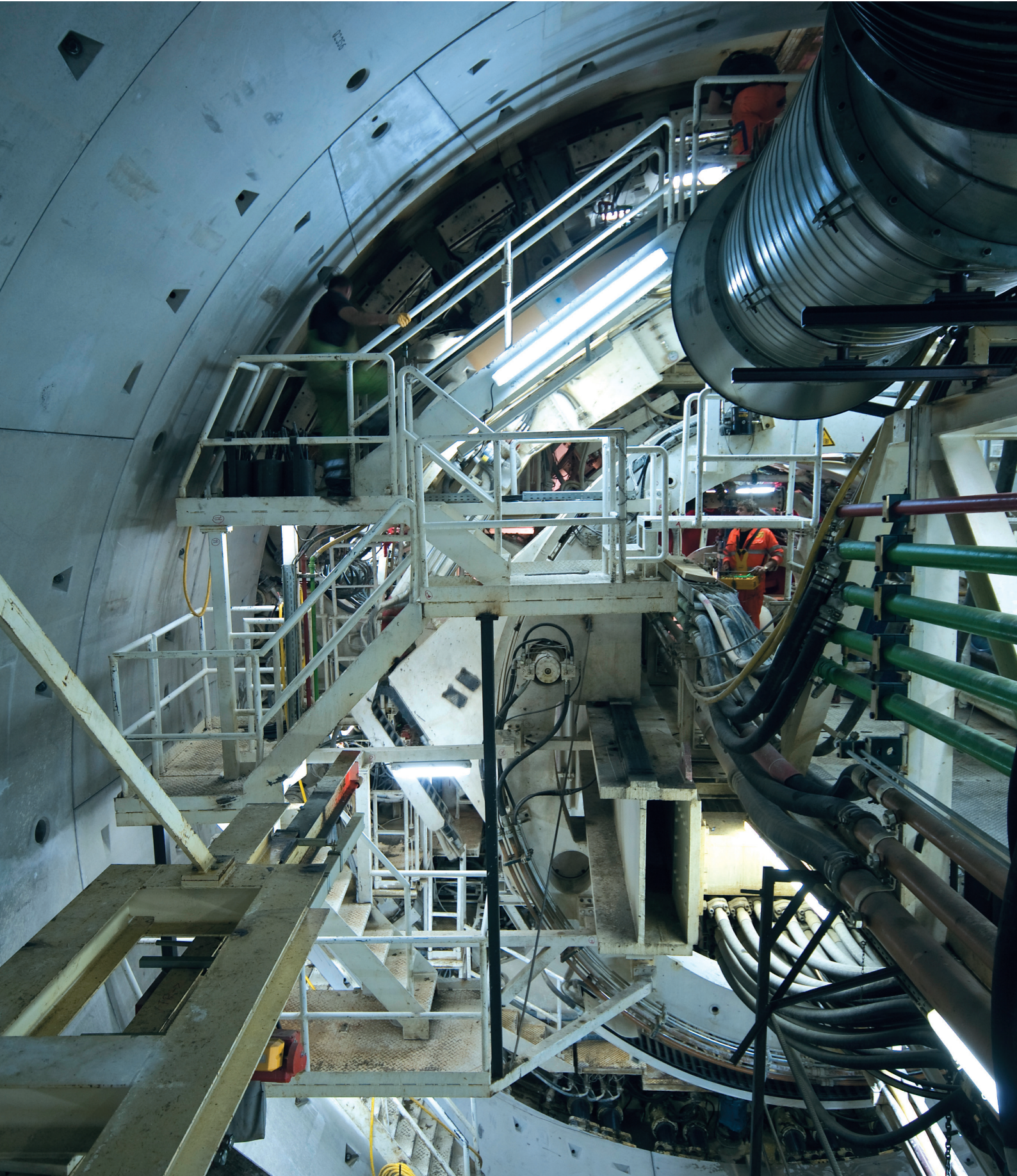

CONTENT

The evolution of Fiber Reinforced Concrete (FRC)	4
Advantages of FRC in precast tunnel segments	4
An introduction to the behavior of FRC	4
Conditions for efficient load transfer	5
Precast segment performance criteria	5
The flexural (3-point) bending test	6
A fiber product proposal for precast tunnel segments	8
Characteristics of Dramix® 4D steel fibers for FRC	9
Conclusion	10

WHITE PAPER

Choosing the Right Fiber for Fiber Reinforced Concrete Precast Tunnel Segments

Benoit de Rivaz, Global Technical Manager BP Underground, Bekaert

This white paper looks at the historical evolution of Fiber Reinforced Concrete (FRC), its advantages in precast tunnel segments, the required performance criteria of FRC for precast tunnel segments, and the technical specifications of a proposed type of steel fiber for this application.

THE EVOLUTION OF FIBER REINFORCED CONCRETE (FRC)

As far back as 1920, an idea was patented to incorporate steel shavings into a concrete mix to increase its strength and stability. However, it wasn't until the 1960s that the modern development of Fiber Reinforced Concrete (FRC) began when it was realized that the cracking tensile strength of concrete (one of its main drawbacks) could be significantly increased by adding fibers. Employed initially for applications such as industrial flooring, in the 1980s FRC began to be used for underground applications, initially using shotcrete (sprayed concrete or gunitite) and then later concrete tunnel lining segments.

Reinforced concrete tunnels linings have traditionally been cast in situ, but the development of tunnel boring machines has led to the invention of precast concrete segmental lining technology, which is one of the most promising applications of FRC. A number of large tunnels have already been built around the world with FRC precast linings. The main drivers of this evolution are improved ductility, greater durability, and easier and more cost-effective manufacturing and construction processes.

The fib bulletin 83 (fib = Fédération Internationale du Béton) based on the Model Code 2010 is the accepted recommendation for the design of FRC for structural precast tunnel segments in underground construction.

ADVANTAGES OF FRC IN PRECAST TUNNEL SEGMENTS

The use of FRC provides several advantages in precast tunnel segments, such as:

- Cracking control during construction phases
- Higher impact resistance
- High durability at final stage
- Reduction of costs
- Sustainability
- Increased productivity.

These specific advantages relating to the adoption of FRC should be evaluated according to the characteristics of each project.

AN INTRODUCTION TO THE BEHAVIOR OF FRC

FRC is a composite material characterized by a cement matrix and discontinuous discrete fibers, which can be steel, polymers, carbon, glass or natural materials. The characteristics of the materials used and their dosage affect the final properties of the FRC.

FRC is also significantly influenced by a range of other factors such as the geometry, the volume fraction and the mechanical properties of the fibers, the bond between the fibers and the concrete matrix, and the mechanical properties of the matrix.

Having said that, the behavior of FRC is more than a simple accumulative effect of the characteristics of the concrete matrix and the fibers. As it's a composite material, its behavior is also impacted by the interaction between the matrix and the fibers, which means the transfer of load from the concrete matrix to the fiber system.

CONDITIONS FOR EFFICIENT LOAD TRANSFER

For efficient load transfer, the following three conditions must be satisfied:

- i. Sufficient exchange surface (number, length, diameter of fibers)
- ii. The nature of the fiber-matrix interface should allow for proper load transfer
- iii. The intrinsic mechanical properties (Young's modulus, anchorage and tensile strength) of the fiber should allow the forces to be absorbed without breaking or excessively elongating the fiber.

For steel fiber reinforced concrete (SFRC), a fiber geometry should always be chosen that is relative to the compactness of the matrix, as characterized by its compression resistance, in order to avoid rupture of the fiber when the matrix cracks. Brittle (fiber tensile strength) failure of SFRC can occur at any age of the concrete, from 1 day to 10 years, and is a consequence of selecting an incorrect fiber type for the concrete, not the age of the concrete.

The ductility and post-crack strength of SFRC are determined by many different aspects, including concrete composition, fiber length and aspect (length/diameter) ratio. A major driver of performance is also a balanced combination of anchorage design, wire strength, wire ductility, and optimum network.

Mix design is also key. By mixing the right amount of aggregates (sand and gravel), one can achieve an optimal density with the lowest volume of pores in between the fine and coarse material, with less mortar required to fill these pores and glue everything together. With FRC, the aim should be for sufficient fine material/mortar (the importance of this increases for higher dosages).

Grading curve of four different FRCs.

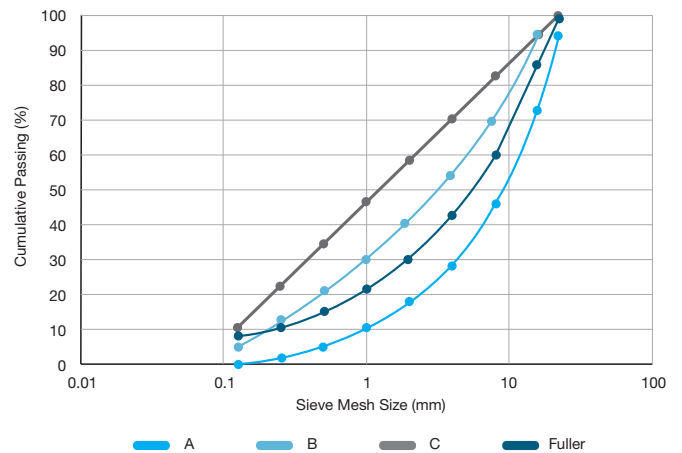

Fig. 1 shows that continuous grading leads to better workability, as fewer “holes” are required to guarantee good workability and stability of the fresh concrete mix. Grading curve B as reference is a good place to start with FRC.

PRECAST SEGMENT PERFORMANCE CRITERIA

The existing technical guidelines, recommendations and codes (in particular fib bulletin 83 based on Model Code 2010) provide the structural engineer with advice on how to quantify the reinforcing properties of steel fibers based on the measured post-crack tensile strength of SFRC.

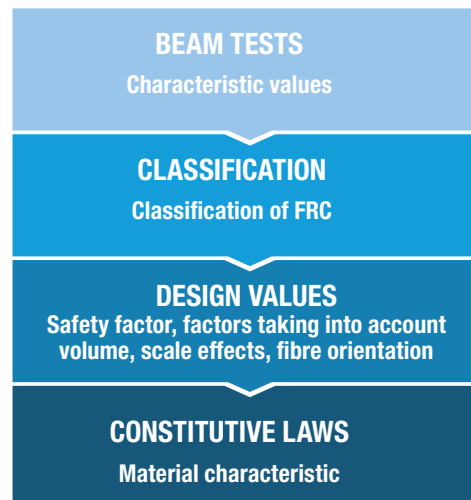

Fig. 2 illustrates the design process involved, from beam tests, classification, design values, and constitutive laws.

THE FLEXURAL (3-POINT) BENDING TEST

In accordance with fib bulletin 83, Model Code 2010, the structural design of SFRC elements is based on the post-crack residual tensile strength provided by the steel fibers. Nominal values of the material properties can be determined by performing a flexural bending test. One of the most common refers to EN 14651, which is based on a 3-point bending test on a notched beam (Fig. 3). In order to obtain statistically reliable results, a minimum of 12 beam tests are recommended.

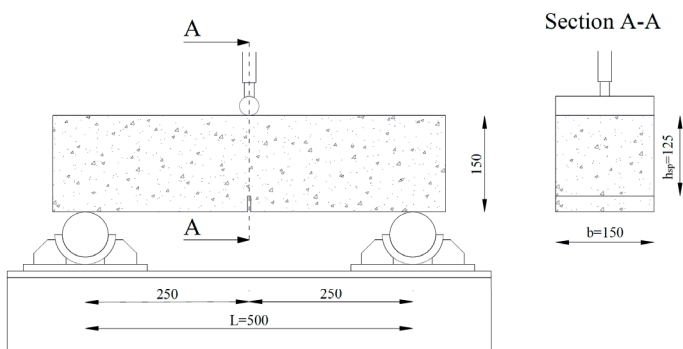
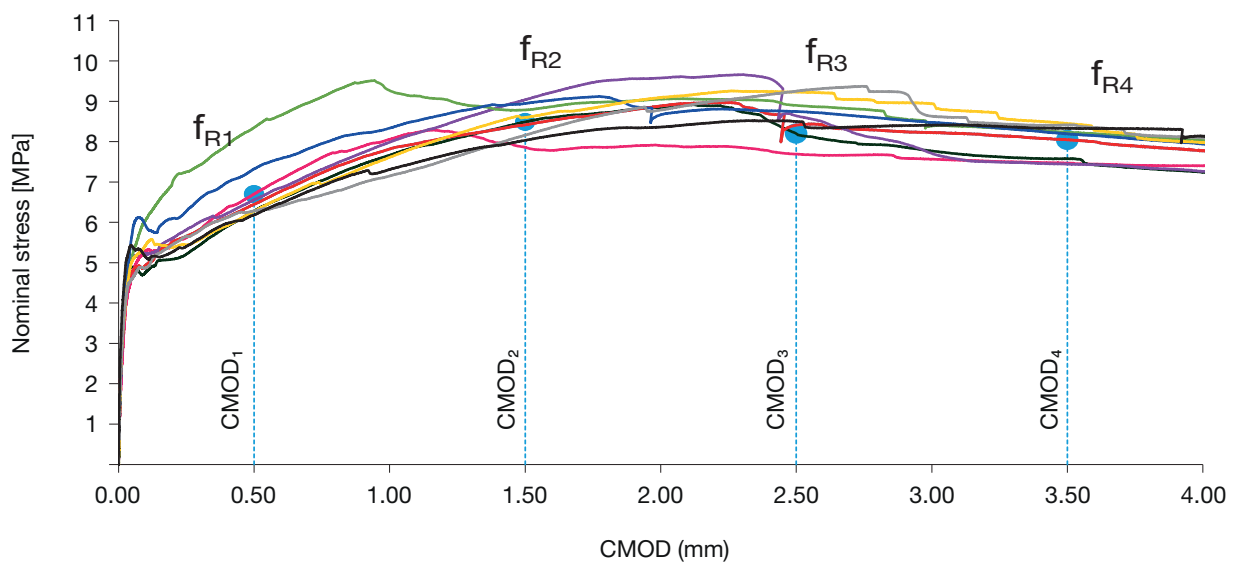

Fig. 3. Test set-up of a flexural (3-point) bending test.



	f_L [MPa]	f_{R1} [MPa]	f_{R2} [MPa]	f_{R3} [MPa]	f_{R3} [MPa]
Beam 1	4.68	6.70	7.86	7.69	7.47
Beam 2	4.90	6.28	8.49	8.20	7.58
Beam 3	4.78	6.45	8.41	8.42	8.04
Beam 4	5.15	6.56	9.04	8.64	7.44
Beam 5	5.72	7.33	8.95	8.75	8.19
Beam 6	5.03	6.27	8.60	9.23	8.45
Beam 7	5.63	7.75	10.2	8.99	8.54
Beam 8	4.60	6.28	8.16	9.25	8.40
Beam 9	5.43	6.18	8.03	8.50	8.33
Average	5.10	6.64	8.64	8.63	8.05
Characteristic	4.30	5.58	7.26	7.65	7.19

Fig. 4. Results of the beam bending tests according to EN 14 651 (with 40 kg of Dramix® 4D fiber)

Fig. 4 shows the results of beam bending tests conducted by Roma University. They show how a low variation provides a performance class type 5e according to MC2010.

The results of such a bending test are expressed in terms of force (F) vs. Crack Mouth Opening Displacement (CMOD).

Parameters $f_{R,j}$ representing the residual flexural tensile strengths are evaluated from the F-CMOD relationship according to the equation below (simplified linear elastic behavior is assumed):

$$f_{R,j} = \frac{3F_{R,j} I}{2bh_{sp}^2}$$

Where:

$f_{R,j}$ is the residual flexural tensile strength corresponding to $CMOD = CMOD_j$

$F_{R,j}$ is the load measured during the test (kN)

I is the span length (distance between support) = 500 mm

b is the width of the beam = 150 mm

h_{sp} is the distance between the tip of the notch and the top of the beam = 125 mm

From the above residual flexural tensile strengths, the characteristic values can be evaluated as follows:

$$f_{R,jk} = f_{R,jm} - k \cdot Vx$$

Where:

k is the student's factor dependent on the number of the specimens (12 beams is recommended)

Vx is the standard deviation of the test results

The standard deviation could be influenced by many parameters such as mix design, casting, and testing, and is also strongly influenced by the fiber number and network effect. A higher fiber network leads to a lower standard deviation, which is key to achieve the required characteristic value for design.

For the classification of the post-crack strength of FRC, a linear elastic behavior can be assumed, by considering the characteristic residual flexural strength values that are significant for serviceability ($f_{R,1k}$) and ultimate ($f_{R,3k}$) conditions.

Two parameters are especially important, and need to be specified by the designer, namely:

- $f_{R,1k}$: the minimum value for SLS
- $f_{R,3k}$: the minimum value for ULS.

Materials with f_{R1k} ranging from 4.0 MPa to 5.0 MPa are commonly used for precast tunnel segments without any bar reinforcement, combined with a f_{R3k}/f_{R1k} ratio in the ranges $0.9 < f_{R3k}/f_{R1k} < 1.1$ or $1.1 < f_{R3k}/f_{R1k} < 1.3$ (class c or class d respectively, according to the Model Code 2010 definition).

Hardening post-crack behavior at section level (through a beam test) immediately allows for crack control and for SLS design.

A FIBER PRODUCT PROPOSAL FOR PRECAST TUNNEL SEGMENTS

In recent years, demand has been increasing for higher compressive strengths for the precast segment from C40 to C70. This has been driven by the need for more structural requirements, to address durability issues, and early age demolding for increased production capacities.

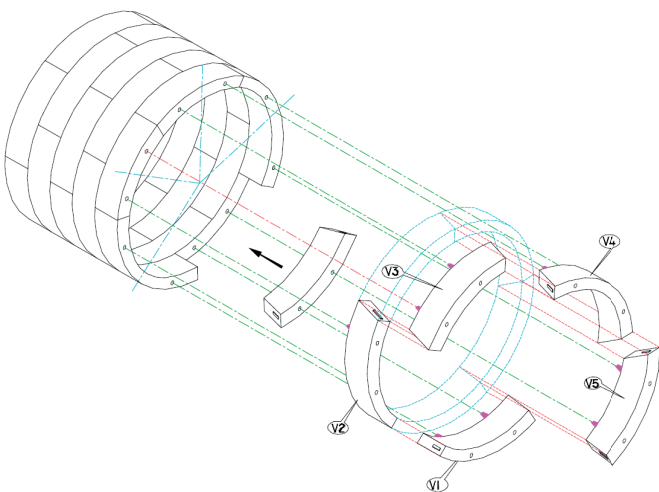

Fig. 5 illustrates a typical precast tunnel segment.

The increase in concrete strength with age and hence better bond to the fibers led to fiber failure in the cracks rather than bond failure, resulting in a much more brittle behavior. Fibers provide a more ductile behavior when they are gradually pulled out.

The hooked ends ensure the desired fiber pull-out. This is the mechanism that actually generates the renowned concrete ductility and post-crack strength. Bekaert's Dramix® 4D steel fibers utilize the same principle, which translates into improved anchorage and ductile behavior.

The tensile strength of a steel fiber has to increase in parallel with the strength of its anchorage. Only in this way can the fiber resist the forces acting upon it. Otherwise it would snap, causing the concrete to become brittle. On the other hand, a stronger wire cannot be fully utilized with an ordinary anchor design. Therefore the tensile strength of a fiber has to be perfectly aligned with its anchorage system and its diameter. Dramix® 4D is designed to capitalize on the wire strength to the maximum degree.

Wire ductility and concrete ductility are two different aspects. Dramix® 3D and 4D steel fibers create concrete ductility by the slow deformation of the hook during the pull-out process, and not by the ductility of the wire itself.

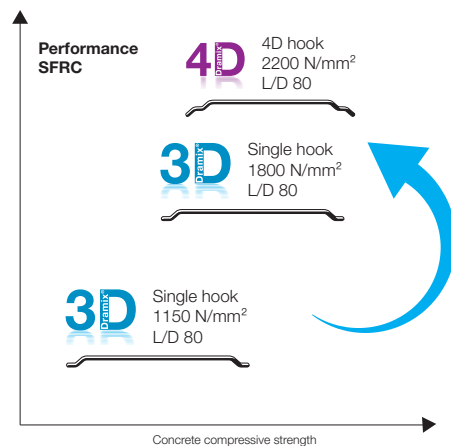

Fig. 6 Steel fiber product evolution based on FRC performance and concrete class

One important point to consider is to keep the same network effect. This is essential to ensure consistent behavior and cracking control.

A fiber with a length/diameter ratio of 80 (60 mm length, 0.75 mm diameter) offers a network higher than 11 km/m³ with a fiber content of 40 kg/m³. A minimum network of 10 km/m³ is recommended; for this a fiber length/diameter ratio of 65 (60 mm length, 0.9 mm diameter) will need a fiber content of about 55 kg/m³. This means that using a fiber diameter of 0.9 mm vs 0.75 mm means that you need to add and pay for about 40% more kg/m³ to achieve the same minimum network. This additional dosage will also lead to side-effects in terms of mixing and workability.

A correct network effect is key to optimize:

- Cracking control
- Post-crack behavior
- Fiber homogeneity and dispersion in combination with glued fiber
- Low dispersion in the result.

Table 1 summarizes the parameters of two common networks.

Length / diameter ratio	65	80
Length (mm)	60	60
Diameter (mm)	0.90	0.75
Fiber/kg	3200	4664
km/m ³ for 40 kg	7.6	11.2

CHARACTERISTICS OF DRAMIX® 4D STEEL FIBERS FOR FRC

After many years of experience, Bekaert specifically designed its Dramix® 4D 80/60BGP (Fig. 7) for precast segments. At a low dosage it offers a hardening post-crack behavior (crack width control, SLS design) and low variation in the result to guarantee a high-performance class according to the MC 2010 classification.

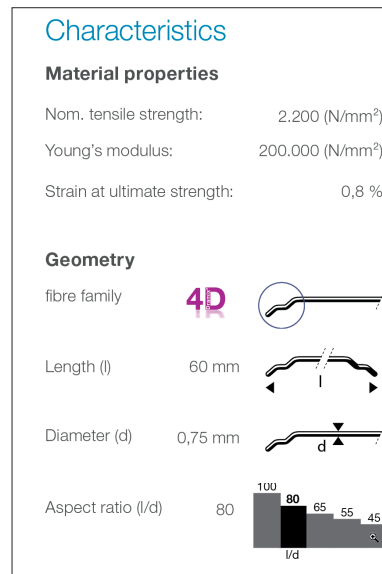

Fig. 7. Fiber characteristics of Dramix® 4D 80/60BGP

Dramix® steel fibers are bundled with water-soluble glue. The glue helps avoid fiber balling during mixing and ensures a homogeneous distribution of fibers throughout the concrete.

Dramix® 4D provides optimal crack control for standard statically indeterminate concrete structures that are submitted to regular static, fatigue and dynamic loadings with high serviceability.

Dramix® 4D Premium is a high performant fiber to create the optimal ductility in high strength concrete.

CONCLUSION

For FRC precast segments to be successful, work needs to be conducted at an early stage of the project on the mix design optimization, while keeping in mind that a composite material is being developed. Bending tests have to be performed according to EN 14651 “Test method for metallic fibered concrete - Measuring the flexural tensile

strength (limit of proportionality (LOP), residual)”. These tests allow the classification of the FRC according to fib bulletin 83, Model Code 2010. Choosing the right fiber for the right performance is essential, but should be done in a structured way to achieve the full benefits in terms of performance, quality and cost of the project.

 **BEKAERT**

better together

INFOBUILDING@BEKAERT.COM

BEKAERT.COM/DRAMIX

Bekaert is a world market and technology leader in steel wire transformation and coating technologies. To be the preferred supplier of steel wire products and solutions, we consistently deliver superior value to our customers worldwide.

Bekaert (Euronext Brussels: BEKB) was established in 1880 and is a global company with approximately 29 000 employees worldwide.

Modifications reserved

All details describe our products in general form only. For ordering and design only use official specifications and documents. Unless otherwise indicated, all trademarks mentioned in this brochure are registered trademarks of NV Bekaert SA or its subsidiaries. © Bekaert 2020

Responsible editor:
Bekaert - 07 2020

