

A large tunnel under construction. The tunnel walls are lined with a grid of rebar. Two workers are visible: one in the foreground on the left, and another in the distance on the right, standing near a tripod-mounted instrument. The tunnel is illuminated from the far end, creating a bright circular opening.

# TUNNELLING APPLICATIONS:

PERMANENT SPRAY  
CONCRETE LINING

*Because we are tunnelling*

 **BEKAERT**

better together

# TABLE OF CONTENTS

---

Introduction	02	Testing method & performance criteria	10
Application field	03	Quality control	19
FRC Design aspect	03	Durability	22
Materials	08	Standard text of specification	26

---

## Benoit de Rivaz

Global Technical Manager



## INTRODUCTION

Traditional excavated tunnels (drill and blast) are used in civil engineering.

Conventionally, tunnels constructed using **sprayed concrete** have been based on a **temporary sprayed concrete lining** to stabilize the opening after excavation and to contain short to medium-term loads. When this lining has fully stabilized, a permanent cast in-place concrete lining is installed to contain long-term loads, provide durability and water tightness.

A waterproof membrane between the temporary and permanent lining ensures water tightness and is called the double shell method. This is referred to as the double shell method.

Sprayed concrete technology has dramatically improved in the use of advanced admixtures and application methods to give durable and high performance concrete.

With this improvement in sprayed concrete quality, tunnel linings were constructed using permanent steel fibre reinforced sprayed concrete instead of conventional in-situ concrete within the temporary sprayed concrete linings, lowering costs and significantly reducing the construction time, particularly in sections of complex geometry such as step plate junctions.

Currently modern sprayed concrete technology equips the tunnelling industry with a more economic tunnel lining system in the form of a single shell of permanent sprayed concrete. This technology provides a structural lining that is durable, watertight and can be surface finished to a degree that is similar to cast concrete.

The use of FRPSCL (Fibre Reinforced Permanent Spray Concrete Lining) allows to eliminate the traditional reinforcement in the precast segment production. Over the last few years, the use of this technology has increased.

In 2013, the fib\* presented the Model Code 2010, a specific part is dedicated to FRC. This document has sparked great interest in the tunnelling community and several publications consider Model Code 2010 as a reference.

This handbook would like to support the designers, contractors and clients in introducing FRPSCL in future projects referring to the existing state of art.

*\*fib: Federation International Beton*



# 1. Application field

FRPSCL (Fibre Reinforced Permanent Spray Concrete Lining) can be used for all type of tunnels in a **wide variety of ground conditions**.

This handbook explains the design, test method and performance of spray concrete reinforced with Dramix® steel fibres when used as **permanent support**.

## 2. FRC Design aspect

### 2.1 Tunnel lining option

**Two general systems can be considered to create a single shield tunnel:**

- The first is a true one step application method for small diameter tunnels, or tunnels founded in stable, dry ground conditions.
- The second approach is a two layer application process where the first layer achieves tunnel stability and the second layer (acting monolithically with the first), is installed by spraying, enhancing durability and water tightness.

In all cases, the emphasis should be on buildability, where simplicity is the key to success, particularly with a method depending on construction team performance.

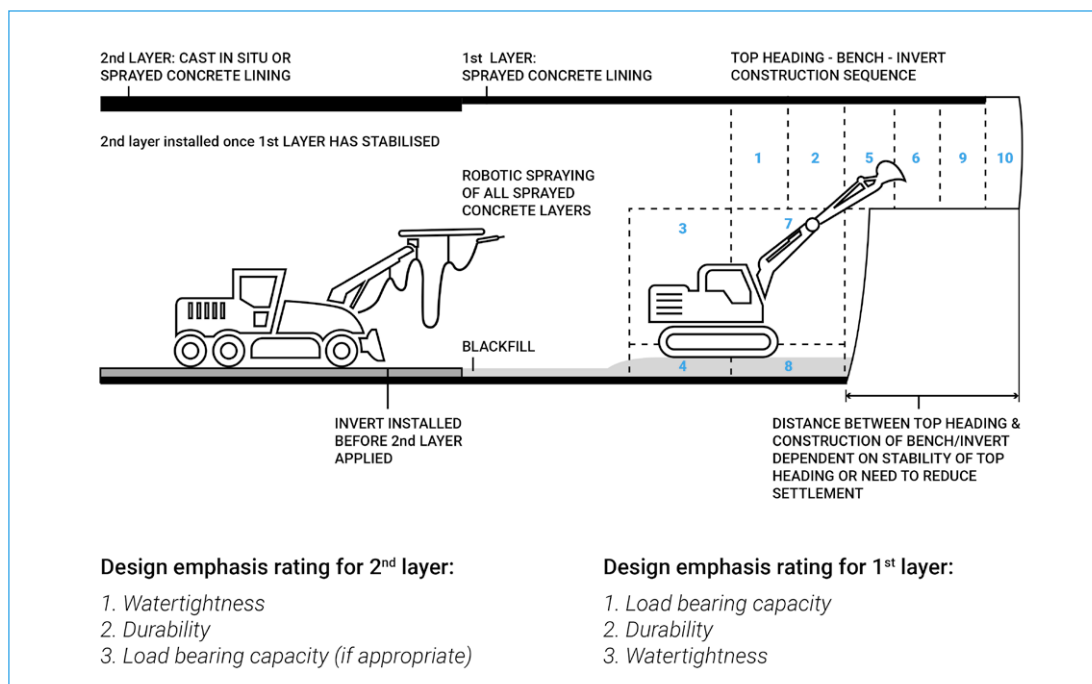

## 2.2 Layer bonding

In order to provide a monolithic structure, the bond between layers must be frictionally tight and form fitting. Shear reinforcement between the two layers should be avoided as it will aid the development of water paths to the inner surface of the tunnel and a consequential reduction in durability. The shear and tensile bond between layers can be ensured by the surface roughness of the first layer to provide an effective, mechanical bonded, interlocking surface.

### How to prepare this layer?

Bond strength is also enhanced by a slow drying and early thermal shrinkage concrete mix design by lowering the heat of hydration and by efficient curing of the fresh concrete.

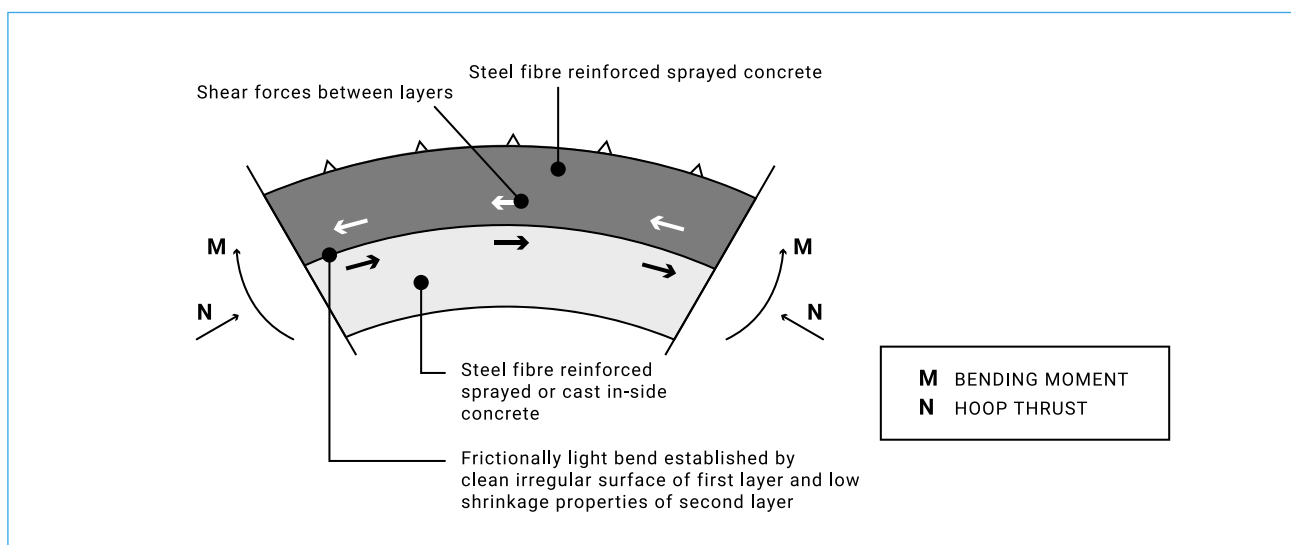

## 2.3 FRC structural design aspect

A permanent sprayed concrete lining should be considered in the same way as any other permanent concrete structure. Hence, codes like Eurocode 2 and ACI 318, should be applied for the design and acceptance of the requirements for normal loading conditions in the long term.

For structural use, mechanical performance of FRC must be verified according to the Model Code 2010 requirements.

The actions on the lining are evaluated with a geotechnical analysis and the use of FRC does not change the global behaviour of the lining. At a geotechnical level, there is no difference between ordinary reinforced concrete lining and FRPSC (Fibre Reinforced Permanent Spray Concrete Lining).

The verification at ULS\* is made by comparing the bending actions and axial forces derived by the geotechnical analysis with M-N envelopes defined at final stage.

\*Ultimate Limit State

"The M-N envelopes at ULS can be defined by imposing the hypothesis of planar section and by considering simplified rigid-plastic behaviour (stress-block) FRC both in compression and tension as suggested in the Model Code 2010 (see APPENDIX 1). The design compressive and tensile stresses are evaluated according to the Model Code 2010.

**Verification at SLS\* can be made considering the two situations:**

1. the lining at final stage is in compression;
2. the lining at final stage is partially in tension.  
See fib bulletin

\*Service Limit State

Let's take advantage of our moment capacity design tool & calculation support. We offer global calculation & design support. Contact us for this personal service.

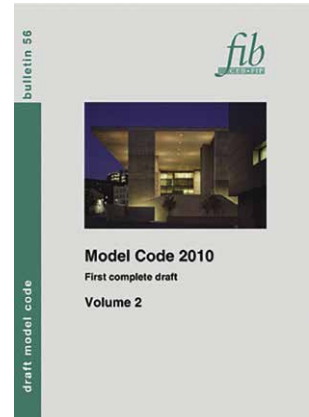

### M-N Envelope

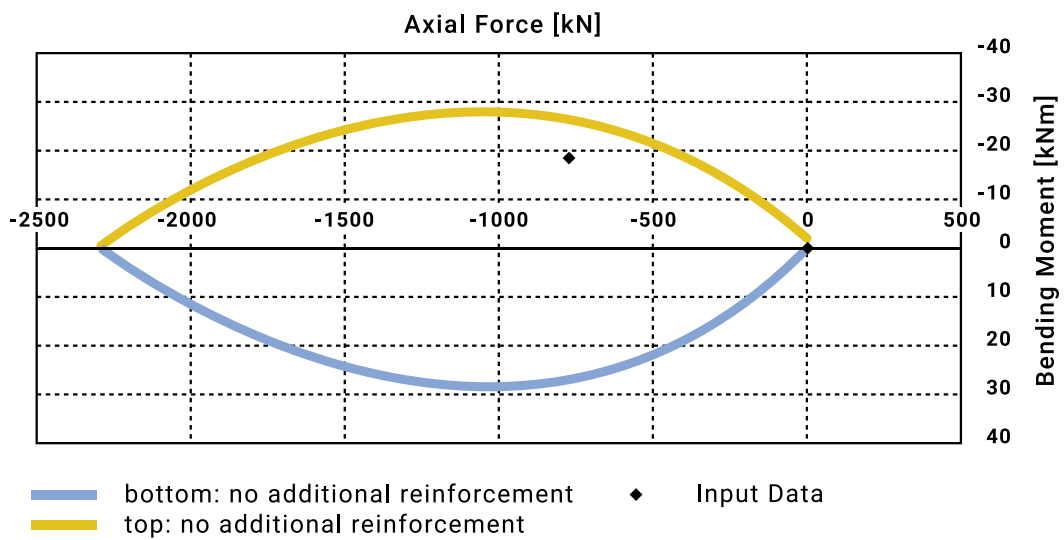

## 2.4 Water tightness

To sustain the long-term durability of a SCL lining which contains either traditional steel bar reinforcement or steel fibres requires that **no persistent flowing water through a crack can be tolerated**.

**This can be achieved in two ways:**

- **CASE A** - Provision of an alternative solution to prevent flow through the lining (e.g. a waterproof membrane, either a sheet type or sprayable solution).
- **CASE B** - Limit the crack widths such that inflows are within acceptable limits.

For **CASE A** it is recommended that the default maximum width for a structural crack be adopted of 0.3mm (Eurocode 2 - Table 7.1N Recommended values of  $w_{max}$  (mm)).

For **CASE B** the maximum it is recommended that the maximum crack width should be 0.05mm for bar reinforced structures and 0.1mm for fibre reinforced structures.

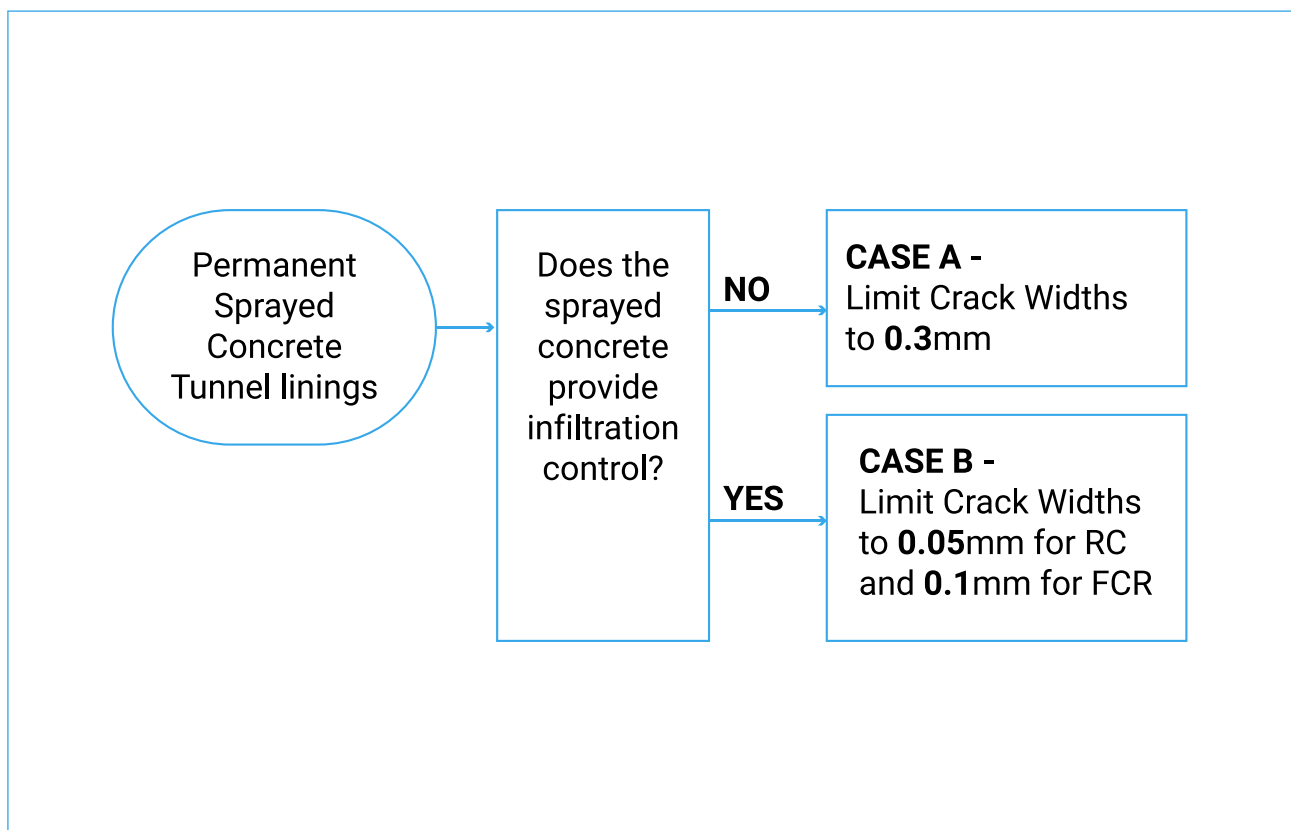







## 3. Material

Fibre Reinforced Concrete (FRC) is a composite material characterized by a cement matrix and discrete fibres (discontinuous). The matrix is either made of concrete or mortar. Fibres can be made of steel, polymers, carbon, glass or natural materials.

The longer the fibre, the better the bond of the steel fibres in the matrix and the more difficult to pull the fibre out of the matrix. It is generally recommended to use a fibre length of at least three times the size of the maximum aggregate used in the matrix.

The smaller the fibre diameter the higher the number of fibres per unit weight and therefore the more efficient the reinforcement becomes and smaller crack widths are achieved.

Steel fibres with a high length/diameter ratio have a better performance.

### 3.1 Hooked ends

Tensile stresses induced in the concrete are transferred to the steel fibres thanks to the durable bond characteristics between both basic materials. The adherence can be improved by enhancing the mechanical anchorage and choosing a suitable shape of the steel fibres. Hooked ends, enlarged ends, crimped wire, ... are different shapes which are available on the market.

### 3.2 Tensile strength

An efficient load transfer will result in a high tensile stress in a small diameter steel fibre. Efficient steel fibres need to have a high tensile strength to avoid fibre fracture. The use of high strength concrete and shotcrete have enhanced the need to develop high tensile steel fibres.

### 3.3 Glued fibres

Good fibres should have a high length/diameter ratio. This can however cause problems when mixing. Loose fibres, particularly those with a high length/diameter ratio, are difficult to spread evenly in the concrete mixture. Bekaert has overcome this problem of "fibre balling" by glueing the Dramix fibres. The glueing of the fibres into bundles guarantees quick and easy mixing for a homogeneous distribution and good dispersion throughout your concrete.

The properties of the composite depend on the characteristics of the constituting materials as well as on their dosage.

Other factors such as the geometry, the volume fraction and the mechanical properties of the fibres, the bond between fibre and concrete matrix, as well as the mechanical properties of the matrix, significantly affect the FRC properties.





The behaviour of fibre reinforced concrete is more than a simple superposition of the characteristics of the concrete matrix and the fibres; to analyze the behaviour of this **composite material**, also the interaction between both has to be taken into account, i.e. the transfer of loads from the concrete matrix to the fibre system.

**Therefore, for efficient load transfer, the following three conditions must be satisfied:**

1. Sufficient exchange surface (number, length, diameter of fibres).
2. The nature of the fibre-matrix interface allows for proper load transfer.
3. The intrinsic mechanical properties (Young's modulus, anchorage type and tensile strength) of the fibre allows the forces to be absorbed without breaking or excessively elongating the fibre.

In fact, in a hyper static mechanical system, the better the cracking is "controlled" as soon as it arises (small openings), the better will be the multi-cracking process and thus the more the structure will tend to show ductile behaviour.

According to ISO 13270: 'Steel fibres are suitable reinforcement material for concrete because they possess a thermal expansion coefficient equal to that of concrete, their Young's Modulus is at least 5 times higher than that of concrete and the creep of regular carbon steel fibres can only occur above 370 °C.'

Optimising the formulation of an FRC with a high fibre dosage does not pose any technical problems as such. This aspect is managed just as easily as the formulation of other cementitious materials.

The method consists in finding the optimal granular skeleton (optimal sand-gravel ratio, coarse/fine aggregate ratio) that produces the best workability, for a given type and percentage of fibres.

Theory and experience both show that the most workable SFRC is the most compact, i.e. the strongest and the most durable.

Practically, the method always uses an already optimised concrete, called the reference concrete, as basis.

**Compared with this reference concrete, optimised SFRC has:**

- a greater sand-gravel ratio, , coarse / fine aggregate ratio.
- more cement paste and/or superplasticiser.

Thus, the higher the fibre percentage, the greater the length-diameter ratio of the fibre and the length of the fibre, the greater the sand-gravel ratio, coarse / fine aggregate ratio, the greater the quantity of cement paste and/or percentage of superplasticiser will be.

### Important notes:

- The workability test is at the basis of the proposed formulation method.
- When one wants to improve the workability of the FRC after optimising the granular skeleton, it is preferable to add cement paste rather than adding superplasticiser. The facings of the structures will then be of better quality, and the tensile behaviour of the FRC will also be better.
- To be mechanically efficient, the fibre length should be three times greater than the diameter of the largest aggregate.
- At fixed workability and at a fixed or slightly varying length-diameter ratio, the shorter the fibre, the higher the dosage that can be used.
- With a little experience, optimisation of an SFRC can take as little as half a working day in the laboratory.

## 4. Testing method and performance criteria

European standard EN 14487-1 mentions the different ways of specifying the ductility of fibre reinforced sprayed concrete in terms of residual strength and energy absorption capacity. It also mentions that both ways are not exactly comparable.

**The energy absorption** value measured on a panel can be prescribed when - in case of rock bolting - emphasis is put on energy which has to be absorbed during the deformation of the rock. This is especially useful for primary sprayed concrete linings (EN 14488-5: Testing sprayed concrete, part 5: Determination of energy absorption capacity of fibre reinforced slab specimens).

**The residual strength** can be prescribed when the concrete characteristics are used in a structural design model.

For PSCL the residual strength will be the key material property to determined.

### 4.1 EN 14651 Test method for metallic fibered concrete - Measuring the flexural tensile strength (limit of proportionality (LOP), residual)

With regard to the behaviour of FRC in tension, which is the most important aspect of FRC, various test methods are possible. Typically, bending tests can be carried out to determine the load-deflection relationship of a beam under either a three point or four point loading. From this, the flexural tensile strength can be determined. Three point bending tests are usually performed in accordance with EN 14651. The figure shows the dimensions of the test beams.

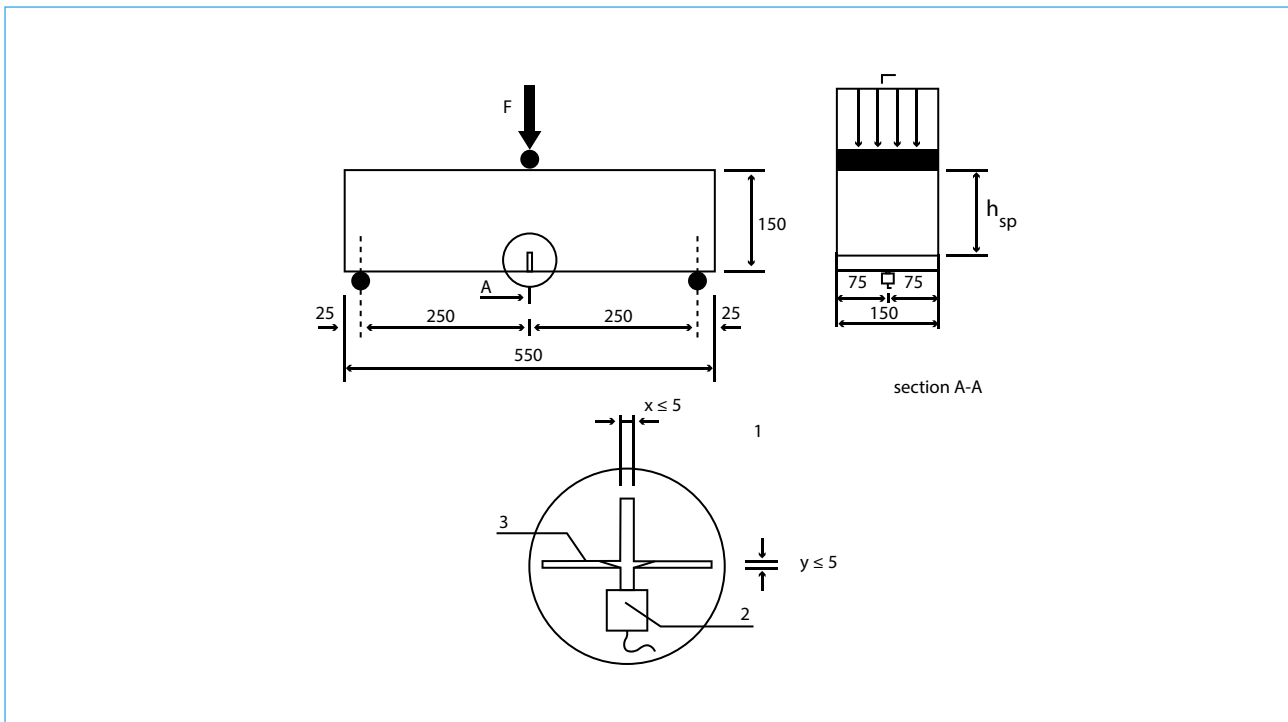

EN 14651 test setup with CMOD transducer

The EN 14651 is a test developed specifically to characterize FRC and derive design parameters. EN 14651 is the reference standard for the European Union CE label for steel and polymer fibres and has been adopted by a number of fibre manufacturers and designers, primarily in Europe, Asia and Middle East. The great advantage of this test is that it relates the strength to specific CMODs (Crack Mouth Opening Displacement) and the strength indices can be used directly in design for the appropriate Limit State. This test procedure has been adopted by Model Code 2010 and its implementation is relatively straightforward and independent of the type of fibre.

Since the use of EN 14651 for characterizing Fibre Reinforced Concrete was demonstrated effectiveness in the structural design (typically precast segment tunnel lining) with strain hardening materials in bending, the use of ASTM C1609 seems to excessively underestimate the residual strength.

**It has to remark that the use of a 3 point bending configuration on notched specimen (EN 1465 1) is suitable for characterizing a FRC material since it reduce the structural effects on the tests.**

**The residual strength indices which are of greater importance, according to fib Model Code 2010, are:**

- Value  $f_{R1}$  (CMOD = 0.5mm) is used for the verification of Service Limit State.
- Value  $f_{R3}$  (CMOD = 2.5mm) is used for verification of the Ultimate Limit State



**The RILEM and MC2010 design methods are based on notched beams because of the perceived benefits of notched samples.** These are that the notch will provide a slower cracking process, thereby reducing the risk of a sudden drop in load. Also notch allows the test to be controlled on the basis of the rate of increase of CMOD and the rate of increase of deflection. Furthermore the test do not introduce structural effect. We focus on the FRC material properties.

With this issue in mind, it is essential that the design method and test method are consistent. This shows that results from different tests cannot be compared directly in some cases and especially considering hardening post crack behaviour.

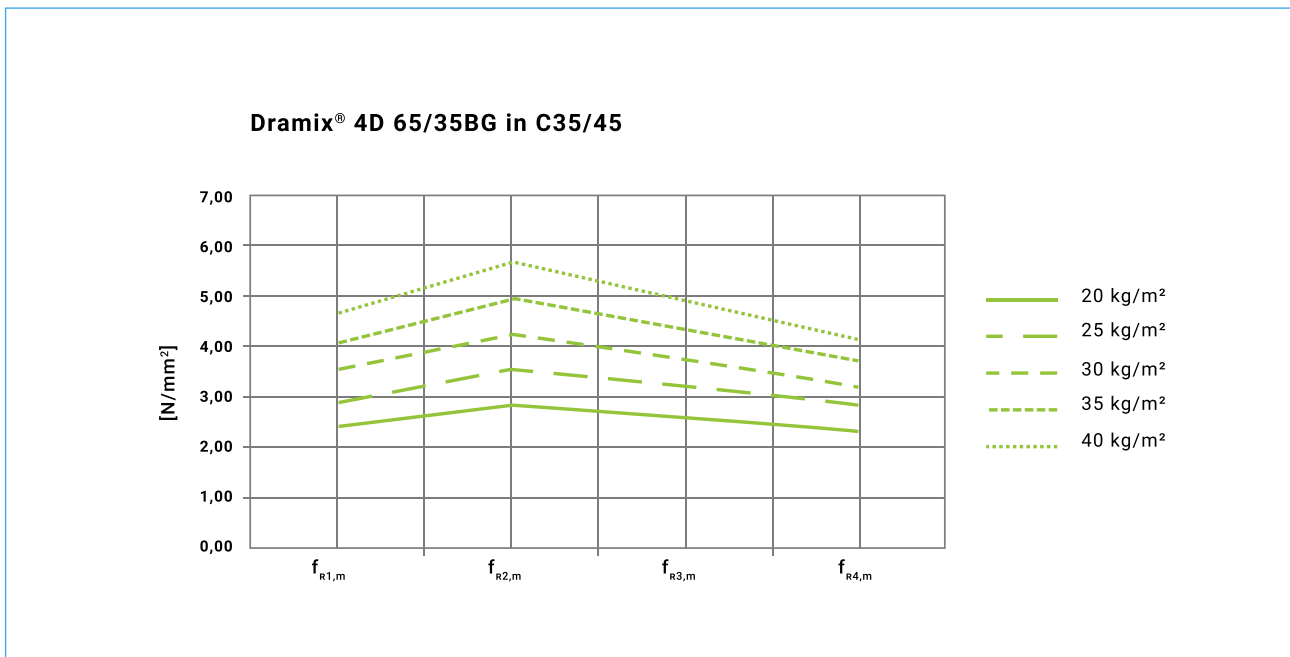

EN Data sheet Gerhard Vitt

**Fibre reinforcement can substitute (also partially) conventional reinforcement at Ultimate Limit State if the following relationships are fulfilled:**

$$f_{R1k} / f_{Lk} > 0.4;$$

$$f_{R3k} / f_{R1k} > 0.5$$

According to the project requirement minimum value of  $f_{R1}$  and  $f_{R3}$  should be specified.

We usually recommend the minimum performance class C35/45 3c according to Model Code 2010 for PSCL.

- Characteristic compressive strength  $f_{ck}$  35 MPa
- Characteristic residual flexural tensile strength  $f_{R1k} > 3.0$  Mpa
- Characteristic residual flexural tensile strength  $f_{R3k} > 2.7$  MPa

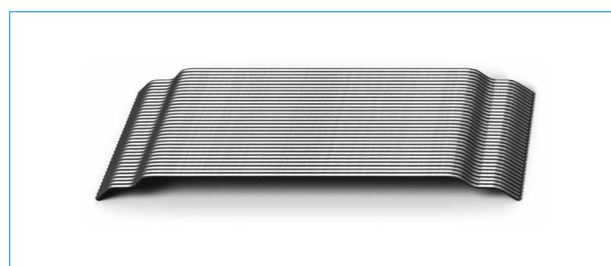

The ASTM 1609 test is performed on a beam (350mm x 100mm x 100mm or 500mm x 150mm x 150mm), without any notch, on a four point loading (word moved) configuration and it requires a servo-controlled closed-loop machine. This test is used widely in North America.

While the crack is free to occur anywhere between the third-points (weak point), experience has shown that it tends to occur near the centre. For a centrally located crack, the maximum crack width for a deflection of 0.75mm is 1.0mm. For a centrally located crack, the maximum crack width at 3.0mm central deflection is 3.5mm.

## 4.2 Alternative test to EN 14651 proposed: EFNARC\* three point bending test on square panel with notch

The design of Fibre Reinforced Concrete (FRC) structures, particularly of FRC tunnels, is often made adopting the indication of FIB Model Code. Model code is considered as reference documents in several guidelines for tunnels.

A practical method to determine the tensile behaviour of SFRC for shotcrete applications is a 3-point bending test on square panels. This test combines the output of the EN 14651 with the advantages of the EN 14488-5 test (the same moulds can be used and due to the larger cracked section, the scatter is lower).

\*EFNARC: European Federation of National Associations Representing for Concrete (est. 1989)

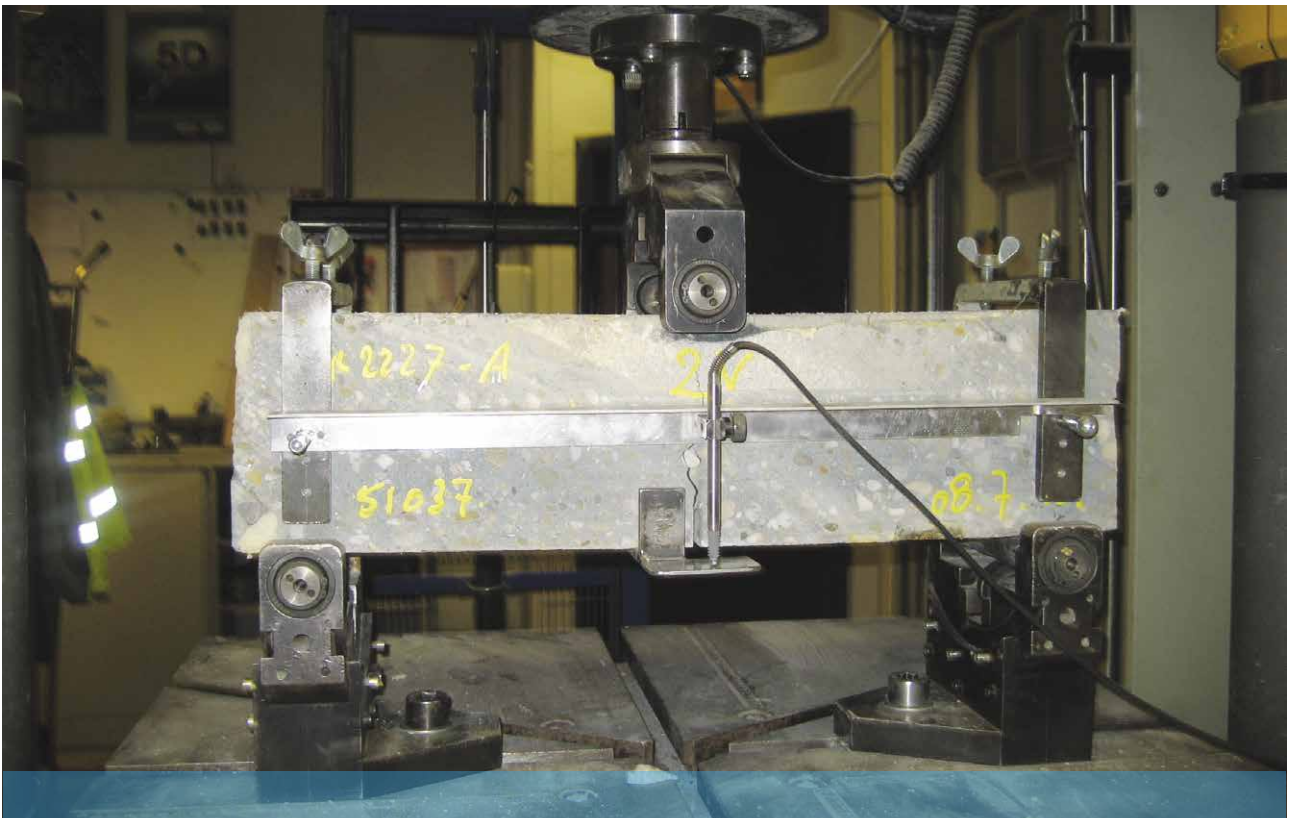

**This test method is promoted by EFNARC for the following main reasons:**

- The geometry and dimensions of the specimens, as well as the spray method adopted will ensure distribution of the fibres in the matrix, which is close as possible to that encountered in the real structure.
- The dimensions of the test specimen will be acceptable for handling within a laboratory (no excessive weights or dimensions).
- The test will be compatible, as far as the experimental means permit, with use in a large number of standard equipped laboratories (no unnecessary sophistication).
- The geometry will be the same as in the plate test for Energy Absorption
- The plate could be sprayed on the job site.
- No need to sawn a prism from a panel which influences the result
- The notch will provide a slower cracking process, thereby reducing the risk of a sudden fall
- By analogy with EN 14651, this test defines the residual flexural strength ( $f_{R1}, f_{R3}$ ) according to the updated international standard (MODEL CODE 2010). The mechanical property obtained will serve as input for the dimensioning method.

The slab specimens need to be prepared according to the regulations of EN 14488-1.

A mould with inner dimensions 600 x 600 mm, and an inner thickness of 100 mm shall be positioned within 20° of the vertical (unless another orientation has been specified) and sprayed with the same equipment, operator, technique, layer thickness per pass and spraying distance as the actual work. Immediately after spraying, the thickness of the concrete specimens shall be trimmed to a 1000+5 mm. It is very important to make sure that the spraying side of the specimen is perfectly flat, otherwise problems can be caused during testing.

This requirement is certainly the point to evaluate with more experience from job site and see the best practise to implement in the future.

**We should use very good formwork and smoothen the upper surface immediately after spraying. This is a key requirement in order to:**

- get a perfect three point bending test, as the rollers should be in contact over the whole line with the specimens
- avoid problems in the beginning of the test to stabilize and end up with a perfect linear curve in the elastic part of the test (due to the roller/specimen contact, which is not constant)
- avoid problems to control the test after the first crack



Supports are stiff in one direction and moving in another one.

The notches are made with a table saw. The flat surface, which is in contact with the mould is resting on the plate of the table saw. When the table saw is cutting in this way, the notch depth is not constant over the whole area, but this is not important. The section which is left, is constant in this way, and it is this value which is used during the calculations. To be even closer at the real value, we measure at the two sides, and take the average

The testing machine should be capable of operating in a controlled manner, producing a constant rate of displacement (CMOD or deflection), and have a sufficient stiffness to avoid unstable zones in the load-CMOD curve or the load-deflection curve. A total stiffness of the system of 200 kN/mm (including frame, load cell, loading device and supports) is advised.

All rollers should be made of steel and have a circular cross section with a diameter of  $30 \pm 1$  mm. Two of the rollers, including the upper one, shall be capable of rotating freely around their axis and of being inclined in a plane perpendicular to the longitudinal axis of the test specimen. The distance between the centres of the supporting rollers shall be equal to  $500 \pm 2$  mm.

The load measuring device needs to have an accuracy of 0.1 kN and the linear displacement transducer an accuracy of 0.01 mm. The data recording system should be able to record load and displacement at a rate not less than 5 Hz.



In the case of a testing machine controlling the rate of increase of CMOD, the machine shall operate from the start of the test with a CMOD-increase of 0.05 mm/min and data logging at minimum 5 Hz. When CMOD = 0.19 mm, the machine shall operate at a CMOD-increase of 0.18 mm/min and a minimum data logging of 1 Hz. The test shall not be terminated before a CMOD value of 3.5 mm is obtained.

In case of controlling the increase of deflection, the machine shall start the test with a deflection increase of 0.06 mm/min with a data logging of minimum 5 Hz. When the deflection reaches 0.26 mm, the deflection increase shall be changed to 0.25 mm/min until a final deflection of 4.5 mm, and a data logging of minimum 1 Hz.

If the crack starts outside the notch, the test result should be rejected.

The test results which need to be expressed are the limit of proportionality

(LOP) and the residual flexural strength.

**The limit of proportionality is calculated as:**

$$f_{ct,L} = \frac{3F_L l}{2bh_{sp}^2}$$

where  $F_L$  is the maximum load between CMOD 0 and 0.05 mm or deflection 0 and 0.08 mm.

The residual flexural strength  $f_{R,i}$  needs to be evaluated at four different displacements.

$$f_{R,i} = \frac{3F_{R,i} l}{2bh^2}$$

**where  $F_{R,i}$  is the residual load at:**

- i = 1: CMOD = 0.46 mm or deflection 0.63 mm
- i = 2: CMOD = 1.38 mm or deflection 1.89 mm
- i = 3: CMOD = 2.30 mm or deflection 3.16 mm
- i = 4: CMOD = 3.22 mm or deflection 4.42 mm

**$l$  = the span between the supports (nominal distance 500 mm)**

**$b$  = the width of the concrete sample (nominal value 150 mm)**

**$h$  = the residual height of the concrete sample (nominal value 125 mm)**

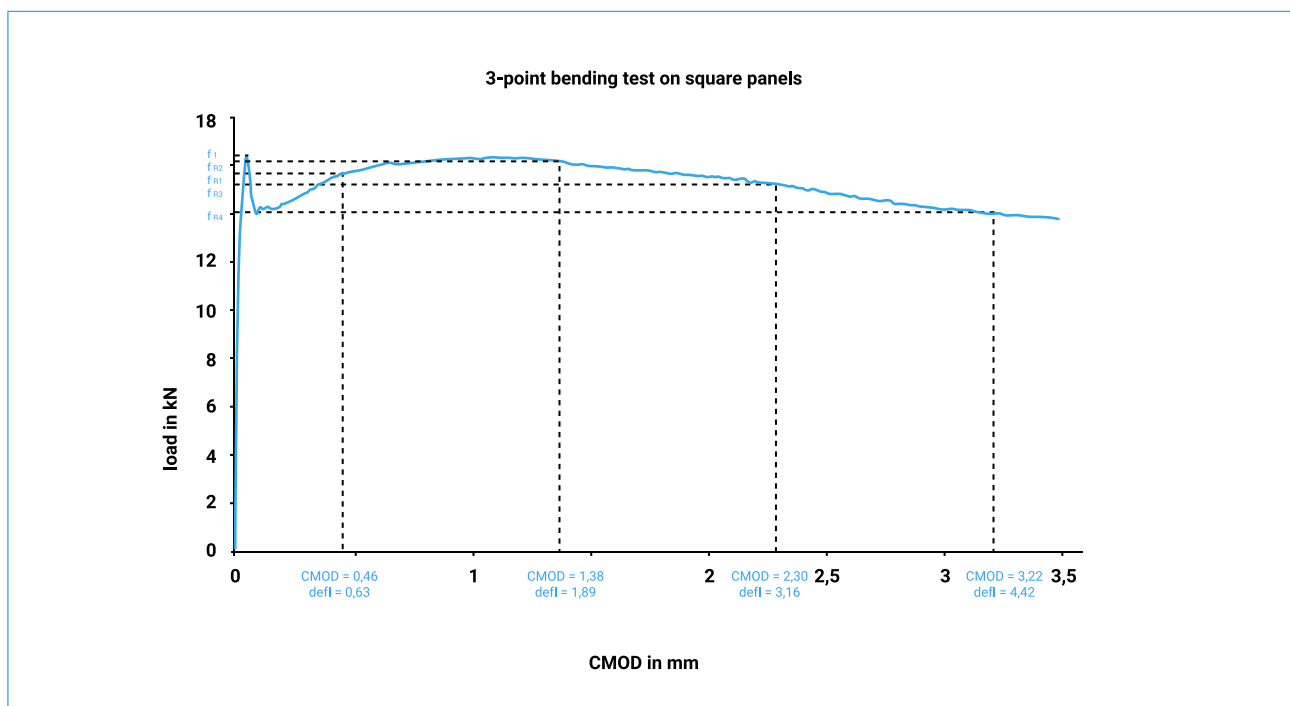

Load displacement curve of a 3-point bending test on square panels

The dimensions of the plates in a 3-point bending test on square panels are different than the dimensions of the beams in the EN 14651 test. Because of this, the relation between the CMOD and the deflection is different as well.

**Three definitions need to be taken into account:**

1. CMOD: crack mouth opening displacement: linear displacement measured at the bottom of the notch of the beam
2. Deflection: linear displacement, measured by a transducer, between the bottom of the notch and the horizontal line which connects the points located in the middle of the beam, above the supports.
3. CO: Crack opening: linear displacement measured at the top of the notch of the beam

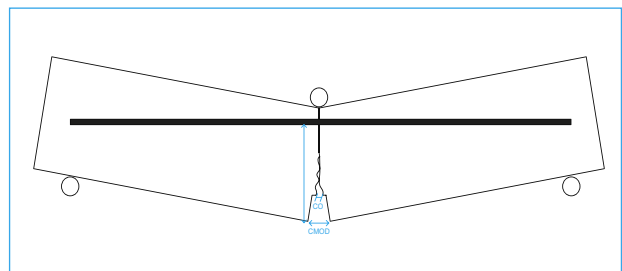
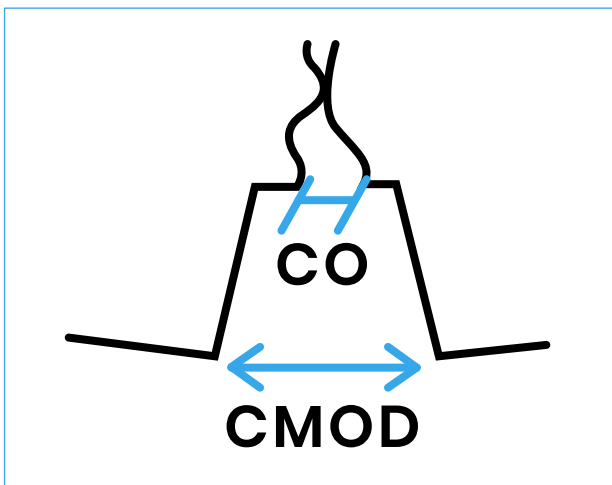

*Definition of crack opening, CMOD and deflection*

**The purpose is to evaluate the 3-point bending test on square panels at the same crack opening as the EN 14651 beam test. The next formulas approach the geometrical correlation between CMOD, deflection and crack opening:**

$$\text{Crack opening} = \frac{4 \times \text{deflection} \times (0,9 \times h)}{\text{span}}$$

$$\text{CMOD} = \frac{4 \times \text{deflection} \times (0,9 \times h + \text{notch depth})}{\text{span}}$$



**Where:**

- span is the distance between the supports (nominal value 500 mm)
- h = the residual thickness of the concrete specimen (nominal 125 mm for the EN 14651 beams and 90 mm for the square panels)
- notch depth is the depth of the saw cut (nominal 25 mm for the EN 14651 beams and 10 mm for the square panels)

**Correlation table between EN 14651 and EFNARC**

	Residual crack strength	CMOD (in mm)	Deflection (in mm)	Crack opening (in mm)
<b>EN 14651 beam test</b>	f <sub>R1</sub>	0.5	0.454	0.409
	f <sub>R2</sub>	1.5	1.364	1.227
	f <sub>R3</sub>	2.5	2.273	2.045
	f <sub>R4</sub>	3.5	3.182	2.864
<b>3 point bending test on square panels with notch of 10 mm</b>	f <sub>R1</sub>	0.5	0.631	0.409
	f <sub>R2</sub>	1.5	1.894	1.227
	f <sub>R3</sub>	2.5	3.156	2.045
	f <sub>R4</sub>	3.5	4.420	2.864

**Ratio between EN 14651 and EFNARC average results for f<sub>L</sub>, f<sub>R1</sub>, f<sub>R2</sub>, f<sub>R3</sub>, f<sub>R4</sub>**

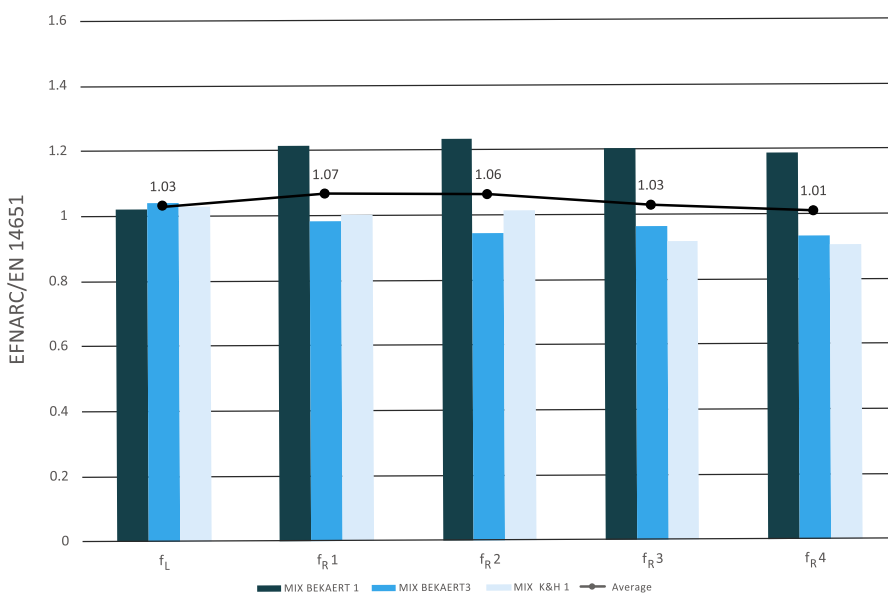

Figure 4.3. Mixes with fiber content 25 kg/m<sup>3</sup>

# 5. Quality control

A procedure for the control of Fibre Reinforced Concrete performance have to be defined in the design process.

**Usually a quality control procedure considers two steps:**

- initial qualification of the material (trials testing);
- tests during the spray concrete lining production (production testing).

## 5.1 Prequalification test

Before starting the permanent spray concrete lining, compressive and bending tests (EN 14651 cut from spray panel or EFNARC three point bending test on square spray panel) have to be performed in order to control the fulfillment of the characteristic values defined in the design. In addition, tests can be suggested to be carried out in order to verify the fiber content or the fiber orientation.

In order to check the compressive properties of the concrete, the same procedure adopted for ordinary spray concrete should be followed.

For the definition of the tensile properties of the FRC, tests according to EN 14651 cut from spray panel or EFNARC three point bending test on square spray panel can be performed. The material should be classified according to Model Code 2010: characteristic values of the FRC residual strengths ( $f_{Lk}$ ,  $f_{R1k}$  and  $f_{R3k}$ ) have to be determined.

In this phase it is suggested to perform at least 12 specimen tests according to EN 14651 or EFNARC three point bending at 28 days of curing.

**The test results can be considered positive if:**

- the characteristic value of  $f_{R1k}$  is higher than the design one;
- the ratio between  $f_{R3k}$  and  $f_{R1k}$  fulfills the design prescription; if a higher strength ratio is obtained the material can be accepted (if no specific prescriptions are present in the design);
- the fulfillment of the Model Code 2010 prescription for substituting the traditional reinforcement with fibre is verified ( $f_{R1k}/f_{Lk} > 0.4$  and  $f_{R3k}/f_{R1k} > 0.5$ ).

In order to define the characteristic value from the tests results, the procedure suggested in Eurocode 0 can be used. The average value  $m_x$  and the coefficient of variation  $V_x$  are defined,

$$S_x = \sqrt{\frac{\sum (x_i - m_x)^2}{(n - 1)}}$$

The value of  $k_n$  is defined according to ISO 12491, with the use of a Student's distribution, with  $u_{0.05}$  fractile of the t- distribution for the probability 0.05.

Value of  $k_n$  for different number of specimen are reported in Table 1.

The aforementioned procedure is based on the assumption that the coefficient of variation  $V_x$  is unknown.

In Model Code 2010 a relationship between average and characteristic value is given only for  $f_{R1}$ .

$$f_{Ftsm} = f_{Ftsk} / 0.7 \text{ with } f_{Fts} = 0.45 f_{R1}$$

Table 1.  
Value of  $K_n$  for known  $V_x$

n	$k_n$
3	3.37
4	2.63
5	2.34
6	2.18
8	2.01
9	1.96
10	1.92
12	1.87
15	1.82

**and as a consequence:**

$$f_{R1m} = f_{R1} / 0.7$$

The relationship proposed in Model Code is based on a coefficient of variation equal to 0.20. There are many data available in the literature coming from large production that can confirm this data. It has to be noted that the dispersion of the results depends from different factors (fibre content, fibre geometry, concrete rheology...).

If data are available from large production of a similar material (e.g. using same fibre and same fibre content) the coefficient of variation can be considered known.

**In this case the coefficient  $k_n$  is equal to:**

$$K_n = u_{0.05} (1+1/n)^{0.5}$$

With  $u_{0.05}$  fractile of the standardized normal distribution for the probability 0.05.

Value of  $K_n$  for different number of specimen are reported in Table 2.

In order to verify possible changes in the post peak tensile behavior with the time is also suggested to have some tests performed on samples at 56 and 90 days.

Table 2.  
Value of  $K_n$  for known  $V_x$

n	$k_n$
3	1.89
4	1.83
5	1.80
6	1.77
8	1.74
9	1.73
10	1.72
12	1.71
15	1.70



## 5.2 Quality control during Permanent Spray Concrete Lining production

It is necessary to perform tests in order to control the quality of the material. A procedure for the quality control during the productions shall be indicated by the designer, who shall take into account the forecast production ( $m^3/day$ ) and the risk of variation of the production testing results through time.

Anyway, it is recommended to perform flexural tests on the FRC and not only compressive tests.

Beam test according to EN 14651 or EFNARC panel can be performed in order to control the residual strengths during the production. It is suggested to test at least 3 specimens for every control.

The conformity control can be made adopting the same approach of EN 206 for concrete in compression.

**If more than 15 data are considered, the mean values should respect the conditions:**

The designer should give indication on of the quality control procedure requirements.



## 6. Durability & Sustainability

The main factor that determines the durability of a concrete structure is achieving a low permeability which reduces the ingress of potentially deleterious substances. Low permeability material is achieved by using the right spray concrete mix design with reduced shrinkage. Control of micro-cracking is also an important parameter. Steel fibres have been used successfully in permanent sprayed concrete tunnel projects to reduce cracking widths to 0.2 mm.

Steel fibres have the advantage over conventional anti-crack reinforcement to be randomly distributed through the entire tunnel lining structure.

**The homogeneous reinforcement allows a redistribution of the tensile stresses resulting in a greater quantity of uniformly distributed micro-cracks of limited width and depth. To obtain durable sprayed concrete, and to ensure the material properties satisfy the requirements of the design, the application process should conform following criteria:**

- to provide a high performance sprayed concrete with minimal variance in quality;
- thoroughly mixed homogeneous concrete, including steel fibres;
- reduce the risk of human influences affecting negatively the quality of the sprayed concrete; robotic spraying mobiles should be used where possible, allowing a good quality sprayed concrete to be applied by a certified operator in safer and more comfortable conditions with a minimum of rebound;
- in case of loose ground and running ground water, the system should be adjustable to provide sprayed concrete with immediate setting characteristics.



Image copyright Crossrail Ltd.

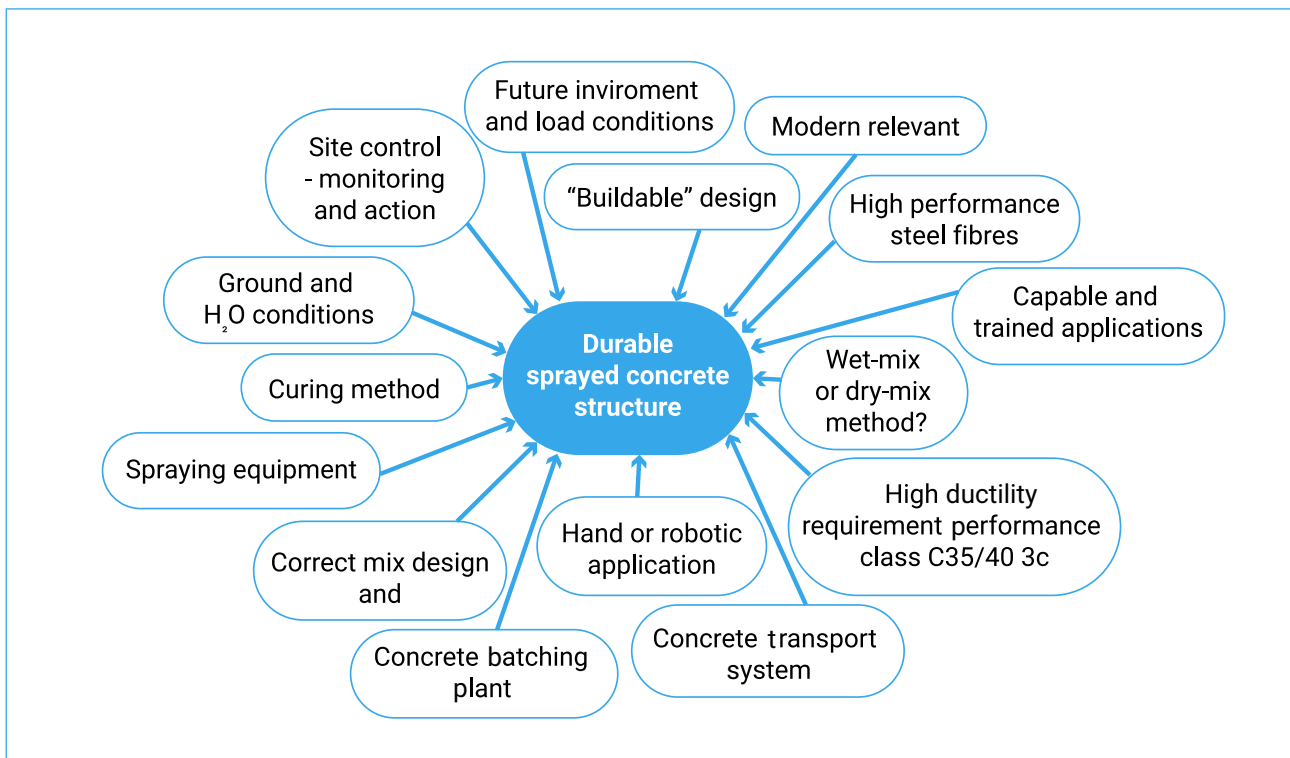

“The durability of SFRC and in particular corrosion of steel fibres has been the pivot of numerous research projects for the past decades. The existing literature on durability of SFRC is vast and covers a broad field, including different deterioration mechanisms and exposure conditions....

**It can be concluded, that SFRC presents an overall improved durability to corrosion compared to conventional reinforcement.”** Fib bulletin 83

**We should keep in mind :**

- When the crack does not exceed 300 µm of opening in fiber-reinforced concrete, it presents a very tortuous and, at times, discontinuous path, which makes the circulation of aggressive agents more difficult.
- When the crack opening does not exceed 300 µm, self-healing mechanisms can occur and the corrosion products (in the case of metal fibers) can be deposited in the interior of the cracks. These two physical mechanisms consequently obstruct the cracks and therefore prevent circulation of aggressive ions.

## Example of return of experience in subsea tunnel

Norwegian Public Road Association has recently updated version (November 2015) of the Process Code 1 - Standard description for road contracts, Manual R761, made changes to the requirements for fibre in shotcrete for rock support. The requirement in process 33.4 Securing with shotcrete now is that fibre should be acc. EN 14889-1 Fibre for concrete, Part 1 steel fibres. This means that only opens for the use of steel fibres in the shotcrete to the rock support.

R & D program Durable structures have had an action within the durability of shotcrete, where extensive investigations in several tunnels have recently been completed. It is then made a compilation of these and previous studies. The result indicates that long-term durability of shotcrete with steel fibres can be addressed by stricter requirements for durability class in areas with saline (M40) in combination with increased shotcrete thickness for given rock mass classes. Implicit in this is also a stricter requirements for the identification of corrosive environments during the geological mapping.

### Environmental Impact:

- Reduction of CO<sup>2</sup> by reducing the steel weight vs. rebar
- No risk of contamination to the oceans marine population and fish population (compared to synthetic fibres)

### Why Permanent Spray Concrete Lining?

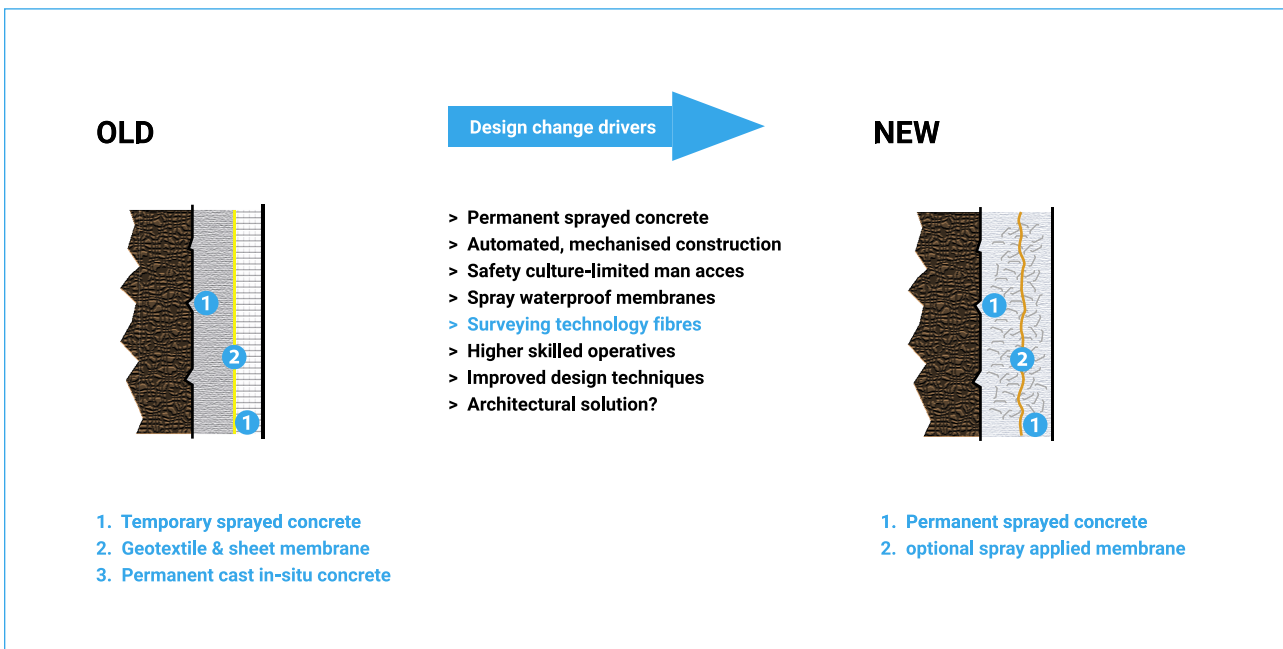

image courtesy of Normet

## Why SFRC?

<b>homogeneous distribution</b>	steel fibres, present close to the surface, ensure excellent reinforcement at the joints of segments
<b>multidirectional reinforcement</b>	steel fibres provide a resistance to stress in all directions
<b>increased load bearing capacity</b>	steel fibres provide a substantial increase in load capacity to first crack and ultimate load at the joints
<b>high impact resistance</b>	the absorbed energy by the steel fibre reinforced concrete during impact is many times greater than the energy absorption of plain concrete
<b>excellent control of shrinkage cracks</b>	the high number of steel fibres present in the concrete ensure a good control of shrinkage cracks
<b>best durability solution available</b>	several research investigations have shown that the durability of steel fibre reinforced concrete (SFRC) under chloride exposure is superior to the one of steel bar reinforced concrete (RC)
<b>product standard</b>	<b>ISO 13 2170</b> : Steel fibres are suitable reinforcement material for concrete because they possess a thermal expansion coefficient equal to that of concrete, their Young's Modulus is at least 5 times higher than that of concrete and the creep of regular carbon steel fibres can only occur above 370 °C.
<b>design standard</b>	<b>Model Code 2010:</b> Perfectly validated for steel fibre.



SFRC (Steel Fibre Reinforced Concrete)

## Economic & Sustainability advantage

- Increase of productivity and time saving
- Elimination of storage and positioning of lattice girders, arches ribs and mesh
- Concrete consumption reduction



# 7. Specifications

## 7.1 Fibres

- Fibres should comply with the European Standard EN 14889-1
- Fibres with CE marking, system 1 (Fibres for structural use)\*\*
  - Fibres out of drawn wire, with a tensile strength of the steel wire  $\geq$  1800 MPa
  - Dimensional tolerances according to EN 14889-1 and ISO
  - Fibre length: 35
  - I/D ratio 65
  - If galvanized min. 30 g/m<sup>2</sup>

## 7.2 Special optimize end hook

- Glued fibres to ensure a good distribution and homogeneity in the concrete. It is prohibited to use loose fibres that cause balls during mixing.
- Steel fibres have to be added by an automatic dosing system
- Type of concrete >C35/45

## 7.3 Performance

### Minimum

We also recommend a minimum total length of wire fibre.

Indeed, in order to ensure the minimum network effect to provide a specific multi-crack process generating the redistribution of the loads through the crack bridging steel, we recommend a minimum steel fibre length per cubic meter concrete of 10.000 ml/m<sup>3</sup>.

\*\* While mentioning quite rightly the CE Marking, system one but only using the 4D Dramix® below we may exclude the potential for 3D Dramix® in this application in some sales regions



**BEKAERT**  
better together

**Dramix®**

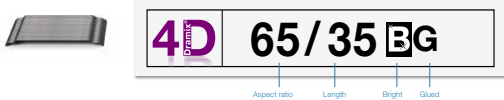

Aspect ratio    Length    Bright    Glued

**DATASHEET**

**Characteristics**

**Material properties**

Norm. tensile strength: 1.850 (N/mm<sup>2</sup>)

Young's modulus: 200.000 (N/mm<sup>2</sup>)

Strain at ultimate strength: 0,8 %

**Geometry**

Fibre family: **4D**

Length (l): 35 mm

Diameter (d): 0,55 mm

Aspect ratio (l/d): 65

**Minimum EN 14889-1 dosage**

15 kg/m<sup>3</sup>

**Fibre network**

8.032 m<sup>2</sup>/m<sup>3</sup> at 15 kg/m<sup>3</sup>

14.232 fibres/kg

**Dramix® family**

3D Typical SFRC applications

4D Supreme serviceability control

5D Advanced structural applications

Tensile strength	3D	4D	5D
Weir ductility	3D	4D	5D
Anchorage strength	3D	4D	5D

**Product certificates\***

**CE**

**Product conformity**

Dramix® conforms to ASTM A620, EN 14889-1 and ISO 13270 Class A.

**System certificates**

All Dramix® plants are ISO 9001 and ISO 14001 certified.

**Packaging**

**BAGS**  
20 kg

**BIG BAG**  
800 - 1.100 kg

**Handling**

**DRAMIX® 4D 65/35BG**

**Optimized anchorage**

Dramix® 4D provides optimal crack control for standard statically indeterminate concrete structures that are submitted to regular static, fatigue and dynamic loadings with high serviceability requirements.

**Glue technology for three-dimensional reinforcement**

Dramix® steel fibres are bundled with water-soluble glue. The glue helps avoiding fibre balling during mixing and ensures a homogeneous distribution of fibres throughout the concrete mix.

**Bekaert construction support**

You can count on our support for each step of your project, from concept design to on-site quality support. Our services include recommendations on each design, construction detailing, concrete preparation and automatic label quality control procedures. We are also happy to share our knowledge with you and your team. Feel free to ask us for a workshop or training on the topic of steel fibre reinforcement in your offices.

For recommendations on handling, dosing and mixing visit [www.bekaert.com/dosingdramix](http://www.bekaert.com/dosingdramix). Any other specific document or certificate can be found on [www.bekaert.com/dramix/downloads](http://www.bekaert.com/dramix/downloads).

Bekaert reserves the right to modify, discontinue or rebrand this product at any time with or without notice. All information contained herein is general and may not be complete. For further details, please contact the local Bekaert office.

Aspect ratio: Vd (length/ diameter)	Minimum kg/m <sup>2</sup> according to min. overlap	l	D	fibres/kg	Total fibre length
40	43 kg/m <sup>2</sup>	30	0,75	9.000	11.610
65	20 kg/m <sup>2</sup>	35	0,55	14.500	10.150

### Method of characterisation – pre-construction test:

**Min. average residual flexural strength is measured with standard EN 14651 beam cut from spray panel or according to EFNARC three point bending test on square panel with notch on spray panel:**

- Number of specimen : 12
- Performance class C35/50 3c
  - Characteristic compressive strength  $f_{ck}$  35 MPa
  - Characteristic residual flexural tensile strength  $f_{R1k} > 3.0$  MPa
  - Characteristic residual flexural tensile strength  $f_{R3k} > 2.7$  MPa

### Bibliography

- Test method for metallic fibre concrete – measuring the flexural tensile strength (limit of proportionality (LOP), residual). EN 1461:2005, April 3rd, 2005.
- fib bulletin 65 - Model Code 2010 final draft volume 1 March 2010
- fib bulletin 66 - Model Code 2010 final draft volume 2 March 2012
- fib bulletin 83 - Precast tunnel segments in fibre reinforced concrete, state of the art fib WP1.41 October 2017
- ISO 13 270: Steel fibres for concrete – Definitions and specifications. (First edition 2013-01-15)
- ASTM C 1609 -10.2010. Standard test method for flexural performance of fibre reinforced concrete (using beam with third point loading).
- Tunnelling is an art: Marc Vandewalle NV Bekaert SA 2005
- SCL Design Optimisation at Bank - A combined lining approach Proceedings of the World Tunnel Congress 2017 – Surface challenges – Underground solutions. Bergen, Norway.
- ITAtech (2013) “Design guideline for spray applied waterproofing membranes”, ITAtech report N°2 - April 2013, ISBN : 978-2-9700858-1-2
- Melbye, T. A. (2005) “Sprayed concrete for rock support”, UGC International, Degussa, Zurich.
- Efnarc three point bending test on square panel with notch (2013)
- Franzen, T. Garsho, K.F. I & Tomisawa, N. (2001) “Sprayed concrete for final linings: ITA working group report”, Tunnelling and Underground Space Technology 16 (2001)
- Brite Euram Project : sub task on durability

## Need more in-depth technical info?

Request our Tunnelling Applications Handbooks via [infobuilding@bekaert.com](mailto:infobuilding@bekaert.com) or download at [www.bekaert.com/underground](http://www.bekaert.com/underground)

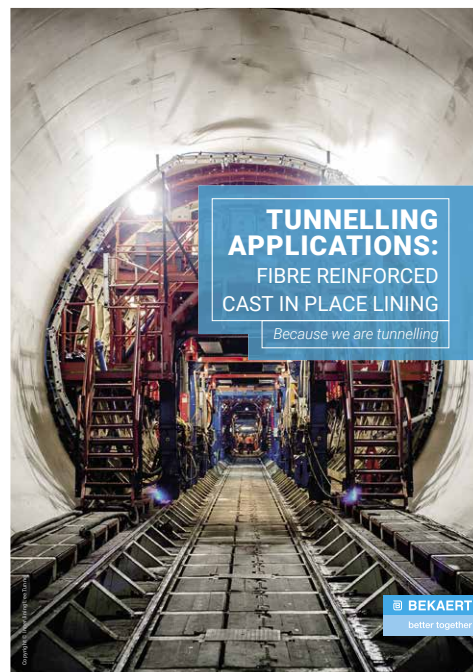
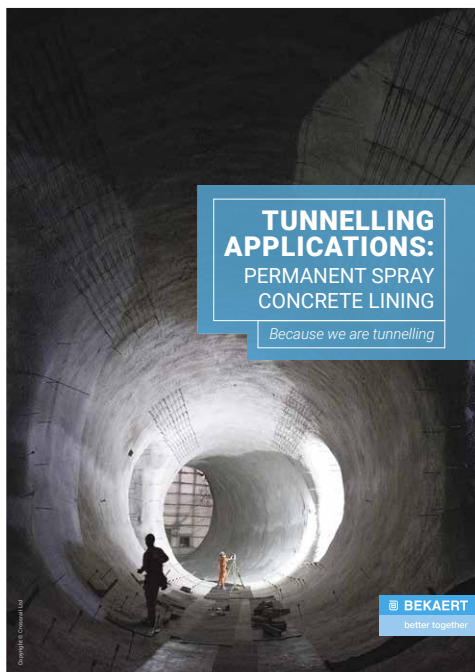
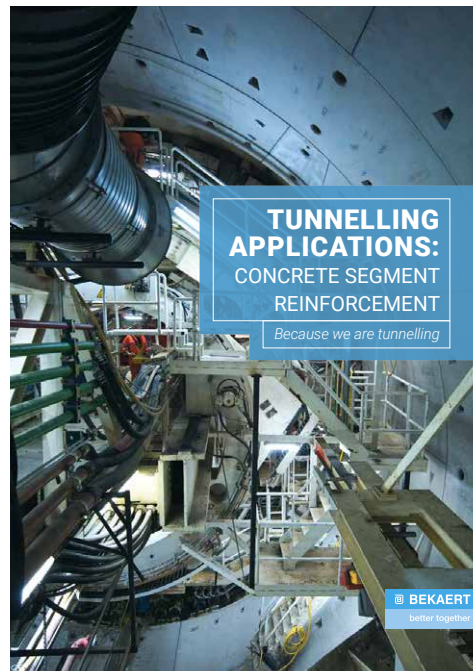
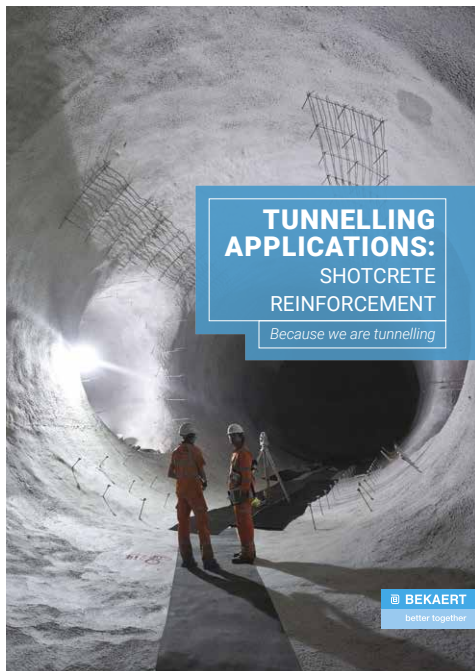

[www.bekaert.com/underground](http://www.bekaert.com/underground)

**Contact us:**

NV Bekaert SA  
Bekaertstraat 2  
8550 Zwevegem - Belgium

[infobuilding@bekaert.com](mailto:infobuilding@bekaert.com)  
T +32 56 76 61 10  
F +32 56 76 79 47